

FT-1529 HEAVY DUTY RANGE

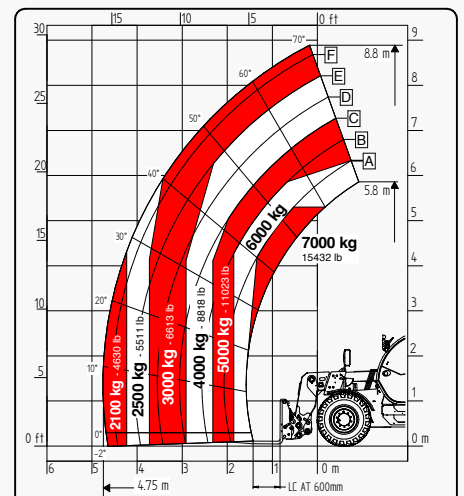

Faresin USA would like to bring to the attention of all potential customers, recipients, and, to the fullest extent possible, external stakeholders, that Faresin Industries S.p.A. has adopted a general disclaimer. This disclaimer pertains to the description of the technical and functional characteristics of its machinery, as well as the methods of their use, including safety considerations. This disclaimer is of a general nature, and Faresin Industries S.p.A. encourages you to review it, which can be accessed through the website: www.faresindustries.com.

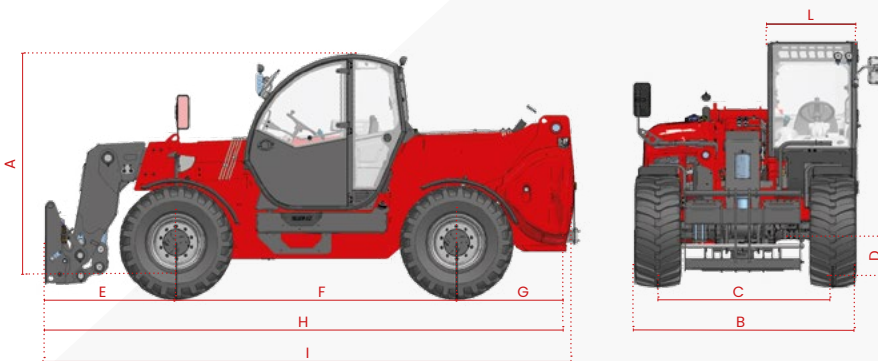

FARESINUSA.COM

877-327-3746

FT-1529 HEAVY DUTY RANGE

TECHNICAL FEATURES

MODELS		FT-1529
DIMENSIONS		
[A] Height	ft	8.3
[B] Width	ft	7.6
[C] Gauge	ft	6
[D] Ground clearance	ft	1.3
[E] Front overhang	ft	4.5
[F] Pitch	ft	9.6
[G] Rear overhang	ft	4.1
[H] Length without tow hitch	ft	18.2
[I] Length with tow hitch	ft	18.4
[L] Cabin width	ft	3.1
WEIGHT		
Classic 74	lbs	23,589
HLS 74	lbs	24,030
VPSe 100	lbs	24,250

MODELS		FT-1529
DETAILS		
Number of extracting sections	nr	1
Max capacity	lbs	15,432
Max lifting height	ft	28.8
Max horizontal boom extension	ft	15.5
Boom extension at max height	ft	0.6
Swinging Angle	°	149
TANK CAPACITY		
Hydraulic oil tank	gal	39.6
Diesel tank	gal	31.7
CONNECTION FOR EQUIPMENT		
FH HEAVY		●

NOTE: All dimensions defined on model with wheels 445/65 R22,5

CONFIGURATION	CLASSIC 74	HLS 74	VPSe 100
TRANSMISSION			
Hydrostatic	two mechanical gears	two mechanical gears	continuous variation
Speed	mph	25	25
ENGINE TIER 4 FINAL			
Builder	Deutz	Deutz	Deutz
Power	kW/hp	74,4/101	100/136
Aftertreatment system	DOC + DPF + SCR	DOC + DPF + SCR	DOC + DPF + SCR
Drawbar pull	daN	8500	10400
HYDRAULIC			
Pump type	gears pump	LS piston pump	LS piston pump
Hydraulic capacity	gal/psi	31.7/3,335	47.6/3,625
TYRES			
445/65 R22,5	●	●	●
Turning radius	ft	14.8	14.8
OTHER			
Joystick	mechanical-electro proportional	hydraulic-electro proportional	hydraulic-electro proportional
Quick coupling	○	○	●
Electro-proportional double acting rear hydraulic connection	○	○	○
Front and rear LED lights	○	○	○
Rear trailer lights socket	○	●	●
6 t fixed tow hook	○	●	●
Engine water pre-heating	○	○	○
Air conditioning	○	○	●
Regeneration valve in ascent	-	●	●
Floating boom	○	○	○
Boom suspension	○	○	○
Manual 6-way diverter	○	○	○
PEB (Boom Electric Socket)	○	○	○
Creeper	○	●	●
Front constant flow	○	○	○
Bucket mode	●	●	●
Pneumatic / hydraulic trailer brake	○	○	○
Frame lateral levelling ±10°	●	●	●

● Standard ○ Optional - Not available